

Fitting Instructions for IPSL Hygienic Wall and Ceiling Cladding

These instructions are intended as a fitting guide and each installer may adapt them to fit their own plans, but the objective remains the same - to create a robust, hygienic, easy to clean and easily disinfected surface which is sealed to the wall.

Basic Method: - To secure and seal all sheets to the wall by sliding them into joints and edge pieces which are screwed to the wall through their wider back sections. The job is completed by fitting internal and external angles in and on corners (and also around doors and windows), which are secured by plastic drive rivets. Beads of quality silicone sealant are used within and behind the installation to make the whole surface watertight. If fitting polypropylene sheets it should be a totally mechanical fix. If using one of the PVC sheets then appropriate adhesives may be used – as supplied by IPSL.

The simpler installation is built with J' Edges, 1-piece 'H' Joints 'and Internal/External Angles.

Alternatives might be Maxbash Skirting at the bottom instead of 'J' Edge, and combining with a ceiling at the top, (see P5). On the some occasions it might be preferable to use a 2-piece joint between the sheets if the wall is very uneven. All 4 Edges of the sheet must be secured and sealed to the wall.

Floor edge. Fix either 'J' Edge (*fig1*) or 'Maxbash' skirting (*fig2*) to the wall, over beads of silicone, enough to seal them permanently to the wall and floor.

Fig.1

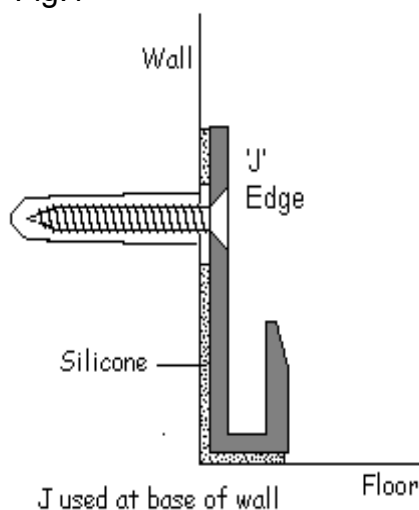
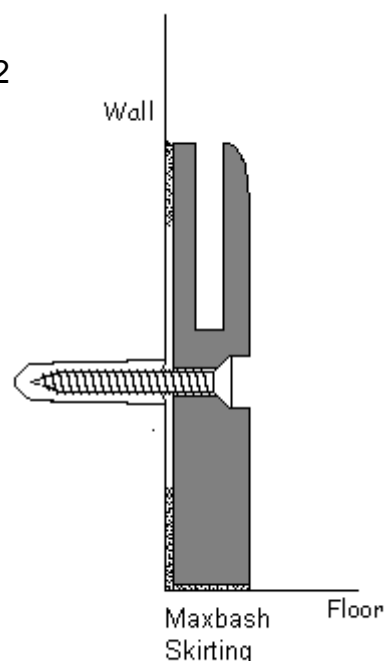

Fig.2



(If you can, installing the bottom edge level and straight will ensure all the sheets sit perfectly upright and make installation much easier.)

(If you are having a welded vinyl floor that is going to curve up the wall, use our 1 piece 'H' joint, *fig4* and ask the flooring contractor to insert the vinyl floor into the slot in the underside)

Ceiling or top edge. Fit 'J' Edge along the top *fig3*.
If you are also fitting a ceiling, you may prefer to trap the top of the sheets with the ceiling, or instead finish with the 2-piece internal corner as a coving
(At all times leave room for expansion)

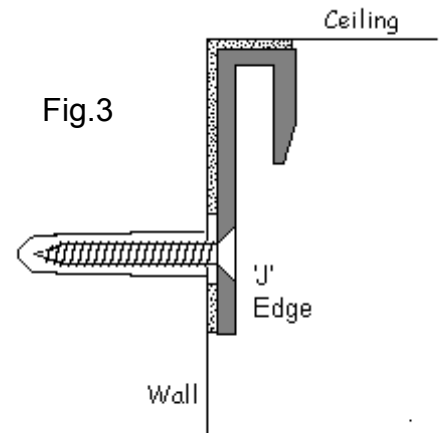

Fitting Sheets. Flex a sheet into the top and bottom 'J' edges and fit a 1-piece 'H' Joint to the vertical edge of the sheet *Fig4*. Leave room for any expansion in the sheet before drilling through and securing the joint to the wall. (Peel the edges of the protective film back now, an inch or two from the edge of the sheet, so it's easy to remove it later when you have finished.) (Cutting an inch off the back of an 'H' joint will let it sit flush to the wall where it meets a 'J' edge.)

Fig.4

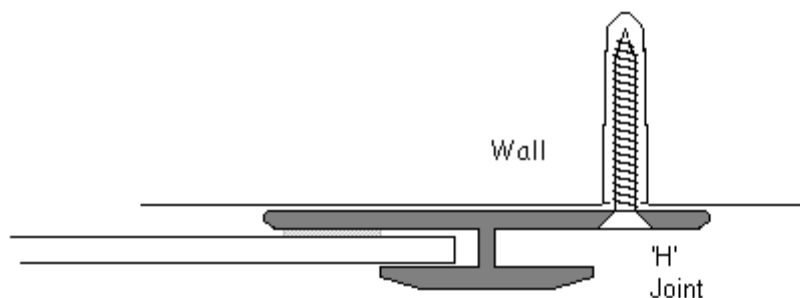

Flex in a second sheet, followed by another joint and so on. Use beads of silicone on the back legs of 'H' joints and 'J' edges to seal the sheets as you build. Always allow for expansion. If fitting polypropylene the fitter may choose to put one or two drive rivets on the centre line of each sheet to aid stability. If fitting PVC then appropriate adhesives may be used.

Corners

The most commonly used corner is the **Internal or External Angle**. (The Internal is slightly more than 90deg and the External is slightly less to ensure a snug fit. The edges are also chamfered opposite ways to be smooth to the wall). Angles are usually secured with drive rivets, however the Universal angle if preferable if fixing by adhesive.

Another style of internal corner can be achieved using the 'J' edge as shown here in *fig.5*.

For non-square corners use the '**Universal angle**'. It comes as a flat profile with a flexible centre and bends to the exact angle required. See Cladding Leaflet. Bend once & leave.

The 2-piece internal corner is an option, but in hygienic environments the voids created behind them could be considered a hazard. However, this option is ideal for use as coving.

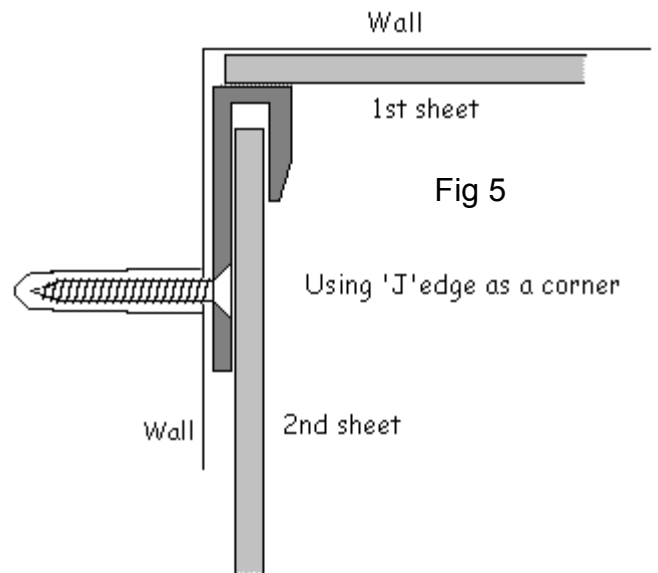

Windows and Doors.

If the window or door has a 'reveal', off cut sheet can be used in the sides, and external angle can frame the whole thing smoothly. If there is architrave proud of the wall then frame with 'J' edge instead.

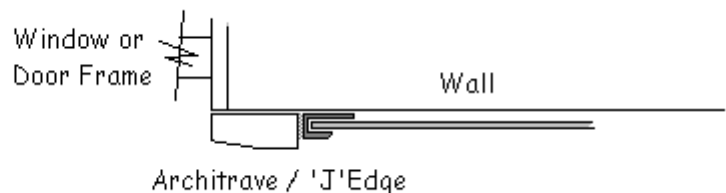
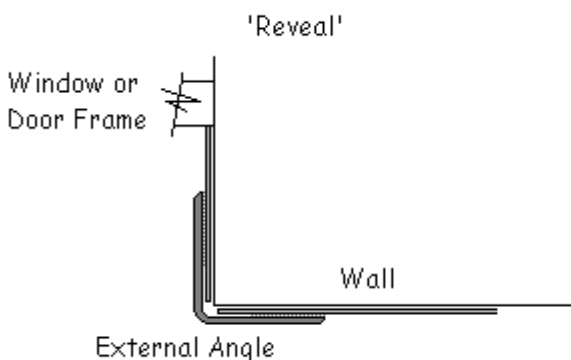

Cutting sheets

Stanley knives can be very dangerous. To minimise the risk of injury please remember to keep fingers away from the line of cut.

POLYPROPYLENE. Using a 'straight edge', score the top surface with a 'Stanley knife' a few times, bend and fold flat back against itself, and carefully slice one piece away from the other. Alternatively, after properly supporting the sheet, use a saw or electric Jig-saw.

MDPVC. Similar to polypropylene but continue with 'Stanley knife' until you have cut all the way through. Or fully support and use a fine tooth hand saw.

HDPVC. Fully support and use saw or electric jig-saw.

Expansion

Everything expands but this will never be a problem if allowed for during installation. An 8ft Polypropylene sheet will expand 2.4mm in height and 1.2mm in width for every rise in temp of 10degC. Expansion in PVC is about 2/3 that of PP.

Adhesives.

PVC can be fitted with adhesive but note that Polypropylene can not.

Polypropylene must be fitted by mechanical methods, (i.e. screws, wall plugs, and drive rivets) IPSL supply an adhesive that is compatible with PVC, please contact us for further details.

2-Piece Joint

If you have identified a need to use the 2-piece joint then fit the aluminium to the wall, pack and fill any gaps underneath. Flex the sheets into the top and bottom edges either side of the aluminium, and apply the PVC cover to hold and seal the sheets in place. (The sheets should only just overlap the aluminium and should not be slid into the joint as this will obstruct the capping strip)

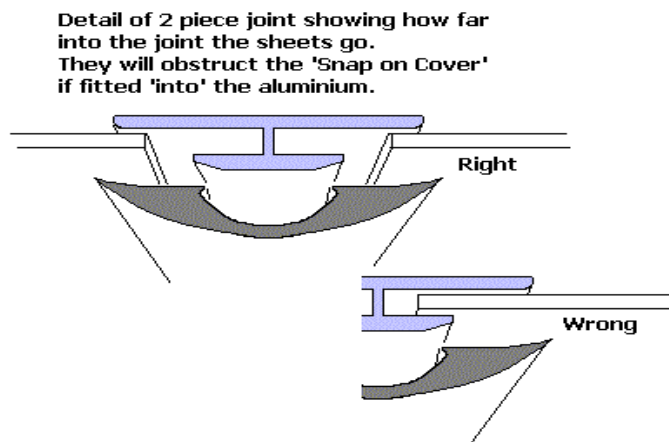

Ceiling

There are numerous ways of finishing around the edge (see pictures) but the basic way of fitting remains the same. Decide on a method of holding the first plank edge in place and fix the leading edge to the ceiling structure through the thin flange which should be on the upper surface. Fit each next plank into the preceding one thus hiding all the fixings as you go. If the ceiling is longer than the planks, complete a whole area up to the length of the plank and apply a joint strip along the edge and carry on.

